

**RSIC-V INSTALLATION GUIDE**  
**RSIC-V SOUND ISOLATION CLIP**

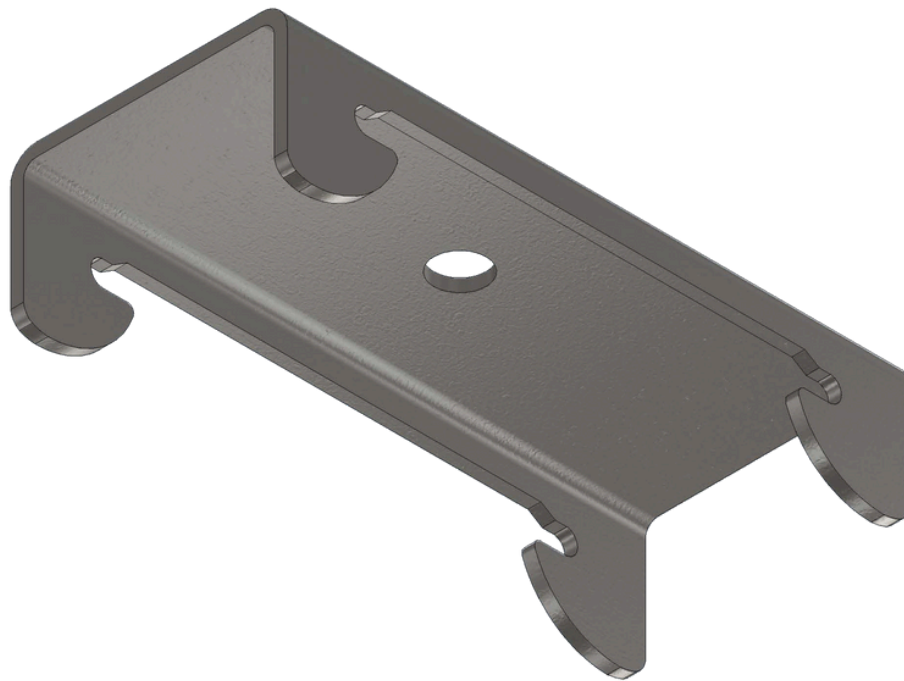

**RSIC-V**



# RSIC-V SOUND ISOLATION CLIP

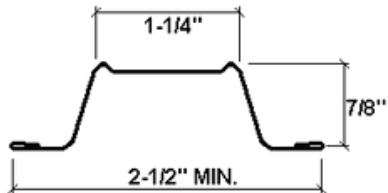

## Furring Channel:

- **Minimum requirements:** 25 gauge, hemmed edge detail required on all 25 gauge furring channel. Meets or exceeds SSMA min. requirements. (25 Ga furring channel recommended)
- **Depth:** 7/8 inch
- **Width Bottom:** 2-1/2 inch wide minimum.
- **Width Top:** 1-1/4 inch wide

Splice drywall furring channel (hat track) with 6 inch overlap in mid span (between two clip) secure with 18 Ga tie wire, or two 7/16" framing screws.

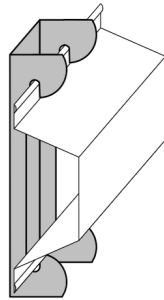

## Resilient Sound Isolation Clip (RSIC-V)

- **Spacing:** maximum 48 inches on center
- **Maximum acoustical design load:** 36 lbs

## Fasteners:

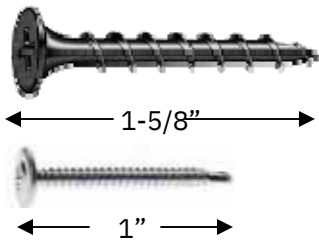

- **RSIC-V to Wood:** 1-5/8 inch minimum size coarse thread screw
- **RSIC-V to Steel:** 9/16 inch minimum size fine thread screw
- For 25 gauge Steel Studs use 9/16" x #8 shank needle point, wafer head framing screw to attach the RSIC-V to the framing members
- DO NOT fasten Resilient Sound Isolation Clips (RSIC-V) to framing members with nails. Use only approved screws.

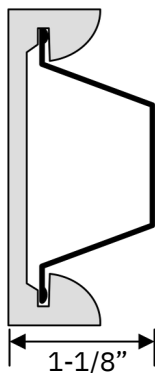

## RSIC-V Dimensions:

- RSIC-V clip 3" tall
- RSIC-V and 7/8" Drywall Furring Channel 1-1/8" deep

## Average Labor Rates:

- **RSIC-V:** 72 clips per man hour
- **Drywall Furring Channel:** 550LF per man hour

Labor rates provided by independent contracting firm

# RSIC-V SOUND ISOLATION CLIP

## Walls: One and Two layer of 5/8" gypsum

- Resilient Sound Isolation Clips (RSIC-V) shall be 48 inches maximum on center. (horizontal)
- Fasten the Resilient Sound Isolation Clip (RSIC-V) to the substrate with a fastener approved for a minimum pull-out and shear of 120 lbs.
- Ensure the RSIC-V clip is tight to the substrate.
- Locate the first row of RSIC-V clips within 3 inches from the floor and within 6 inches from the ceiling.
- Snap in the drywall furring channel (hat track) into the RSIC-V clips (horizontal for walls). (see page 2 for splice details)
- Place 1/4" (minimum) shim on floor to fully support the gypsum board.
- Install the gypsum board from the bottom up leaving a 1/4" min. gap around perimeter of wall.
- ONLY remove the shims after ALL the gypsum board is completely screwed to ALL the drywall furring channels.
- Make sure every screw (floor to ceiling and wall to wall) is installed as required by the assembly design, in every layer of gypsum board before removing the shims at the floor. The shims are critical to ensure best results.
- Caulk around the perimeter of the wall. Use fire and smoke rated acoustical sealant where required.

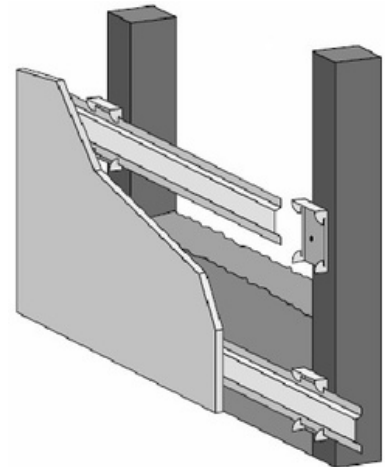

## Ceilings: One and Two layer 5/8" gypsum

- Resilient Sound Isolation Clips (RSIC-V) shall be 48 inches maximum on center.
- Fasten the Resilient Sound Isolation Clip (RSIC-V) to the substrate with a fastener approved for a minimum pull-out and shear of 120 lbs.
- Ensure the RSIC-V clip is tight to the substrate.
- Locate the first row of RSIC-V clips within 8 inches of the wall at each end of a run.
- Snap in the drywall furring channel (hat track) into the RSIC-V clips.
- Install the gypsum board leaving a 1/4" min. gap around perimeter of the ceiling.
- Caulk around the perimeter of the ceiling. Use fire and smoke rated acoustical sealant where required.

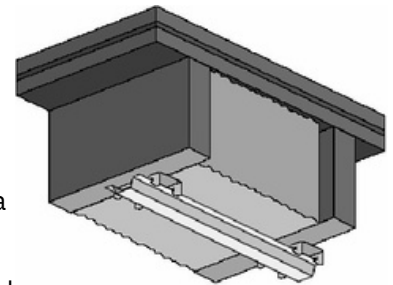

## General Information:

- Refer to [www.UL.com](http://www.UL.com) for complete installation details on all fire resistive assembly designs.
- Resilient Sound Isolation Clip (RSIC-V), furring channel (hat track) and gypsum board shall not carry heavy loads such as cabinets or bookshelves.
- Splice furring channel (hat track) with 6 inch overlap in mid span, secure with 18 ga. tie wire or with two framing screws (7/16").
- Seal all potential air leaks with non-hardening acoustical caulking to achieve best noise control results. Use fire rated sealant where required.
- When attaching the RSIC-V clips to a steel stud the minimum allowable thickness is 20 ga. (0.030).

## Fire Test Information:

Approved for use in over 160 different UL fire resistive design assemblies. Check our website for the latest updates of the fire testing approvals. Check UL Fire Resistance Directory File # R16638 Check UL's web pages [www.ul.com/database](http://www.ul.com/database) Contact UL (877) UL-HELPS

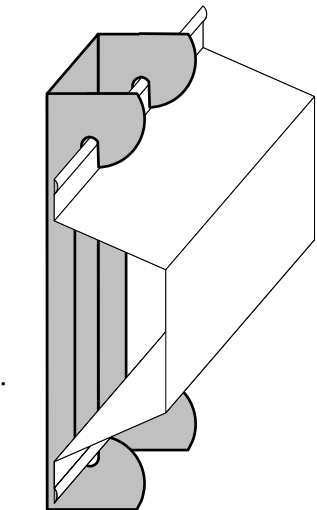

# RSIC-V SOUND ISOLATION CLIP

## APPLICATION RECOMMENDATIONS FOR WALLS AND CEILINGS, WOOD OR STEEL FRAMING

### INSTALLING RESILIENT SOUND ISOLATION CLIPS (RSIC-V)

#### RSIC CLIPS AT 24" OC.

#### RSIC-V Wall or Ceiling System Framing at 24" o.c.

RSIC-V clips at 24" x 48" o.c. 1 or 2 Layers of 5/8" Gypsum Board

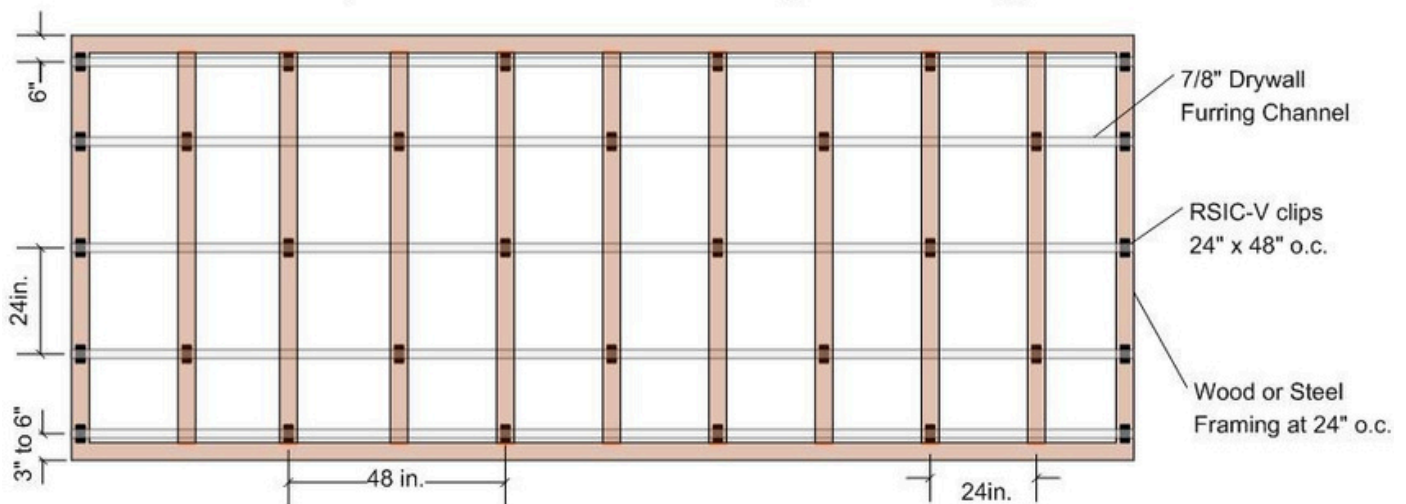

#### RSIC-V Wall or Ceiling System Framing at 16" o.c.

RSIC-V clips at 24" x 48" o.c. 1 or 2 Layers of 5/8" Gypsum Board

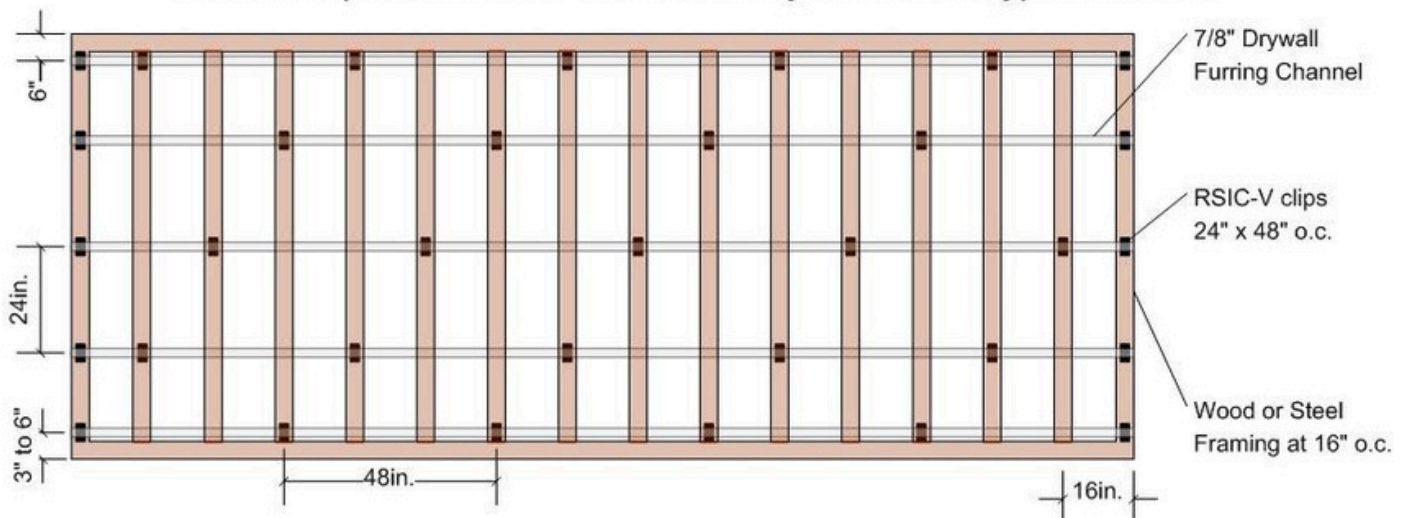

# RSIC-V SOUND ISOLATION CLIP

## APPLICATION RECOMMENDATIONS FOR WALLS AND CEILINGS, WOOD OR STEEL FRAMING

### INSTALLING RESILIENT SOUND ISOLATION CLIPS (RSIC-V)

### RSIC CLIPS AT 16" OC.

### RSIC-V Wall or Ceiling System Framing at 24" o.c.

RSIC-V clips at 16" x 48" o.c. 3 Layers of 5/8" Gypsum Board

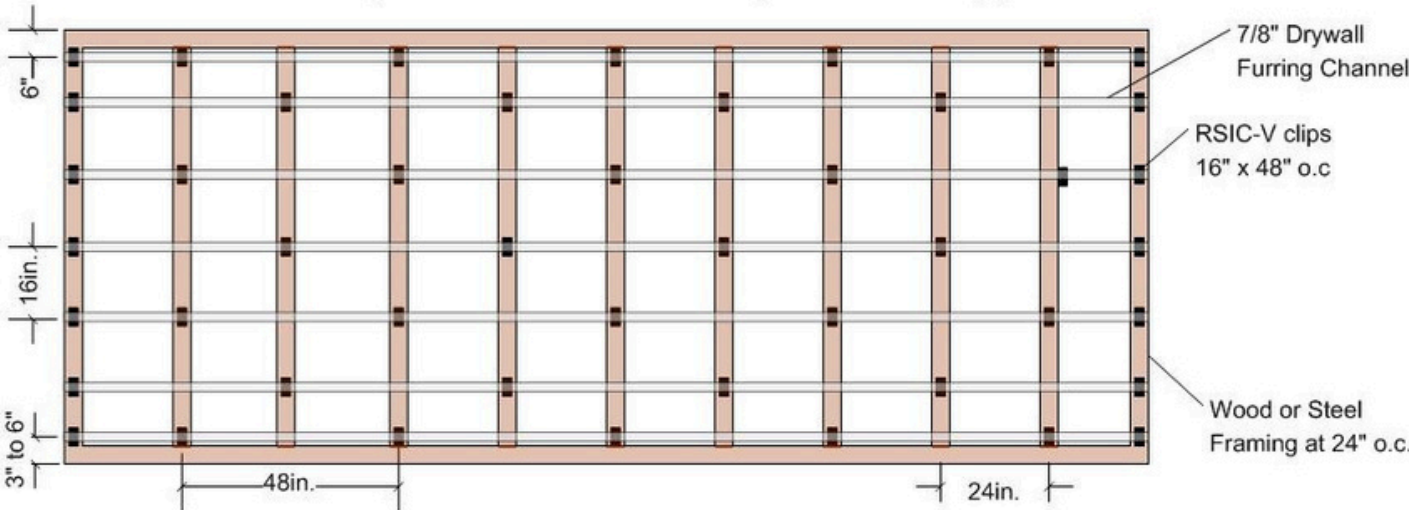

### RSIC-V Wall or Ceiling System Framing at 16" o.c.

RSIC-V clips at 16" x 48" o.c. 3 Layers of 5/8" Gypsum Board

